

WOODSTAR



a star is born ...

WHY WORK WITH WOODSTER GMBH?

- BEST PRICE / PERFORMANCE RATIO
- PRICE LOW – QUALITY HIGH
- QUALITY AND SERVICE BY SCHEPPACH
- SPARE PARTS DISPATCH WITHIN 48 HOURS
- TWO YEARS' FULL SCHEPPACH WARRANTY
- 82 YEARS EXPERIENCE IN WOODWORKING
- CUSTOMER ADVICE BY TELEPHONE
- HIGHLY EFFICIENT SALES PACKAGES
- FLEXIBILITY IN ALL MARKETING QUESTIONS



4 COLOUR PACKAGING WITH SYSTEM

This packaging gives to the end-user the impression of quality and higher value. Also this packaging reduce the personal effort of the salesman in the shops.

name of the article in different languages - international company

Logo „Tim“ will be the Sympathy carrier to the end-user

feel good factor Logo helps user to feel confident about purchasing Woodster products

front view



Logos of the group, gives to the end-user the impression of a big european company (in fact we are a big group)

pictures of versatile use of the machine

this yellow sign should give to the end-user the impression of attention and the end-user will stop on the point of sale

pictographs for your personal in house, shipping companies and certifications

main view



pictographs of technical informations for end-user

NEW

Woodster again takes the lead in consumer problem solving with another great idea with the laminate and wood tile floor saw – sf 05



- The market opportunity was to provide a safe product to cut flooring of all types accurately swiftly and have a low cost portable concept. Mitre saws are not suitable for ripping and often are dangerous with small cuts of wood. The Woodster floor saw solves this issues cost effectively and smartly.
- Versatile cutting machine makes light work of laminate flooring, engineered and real wood flooring.
- Cross cuts and rip cuts using fence guide and free hand
- 860 W induction motor for quiet and reliable operation.
- Dual rail slide system provides accurate cutting performance for the full cutting capacity.
- 11.000 rpm No Load Speed ensures the blade delivers a fine clean surface
- Large table combined with material clamp and protractor for accurate support for cuts at all angles
- Quality 24 TCT blade provides a clean smooth accurate cut with a better finish
- Clear blade guard ensures the operator can see the blade at all times during the cut and set up.
- Lightweight compact design ideal to take direct to the work area and for easy transportation and storage.

Performance data	
Voltage	230 V / 50 Hz
Power rating	860 W
No load speed	11000 rpm
Blade size	125 – 127 mm
Blade teeth	24
Cutting capacity at 90°	52 mm
Cutting capacity at 45°	30 mm
Maximum depth of cut	18 mm
Weight	7.5 kg
Order No	390 1701 000



6 FUNCTION-COMBI

NEW

Combined Universal woodworking machine – Combi 06



The new Combi 06 Universal Machine is the latest addition to the Woodstar family. This machine features a circular saw, shaper/router, planer & thicknesser, mortising attachment and a sawing and tenoning carriage.

It incorporates many of the machines, and fulfills many of the functions, most commonly required by semi professional woodworkers, cabinet makers and joiners. A robust and accurate machine, designed for both workshop & site use.

Carriage	
Carriage dimension	120 x 740 mm
Maximum travel	500 mm
Order No	390 1301 000

Mortising	
Table size	260 x 125 mm
Chuck capacity	13 mm
Slot mortising bits	6 / 8 / 10 mm
Depth stroke	45 mm
Vertical stroke	60 mm
Lateral stroke	95 mm

Performance data

Motor	1.0 kW (1.36 HP)
Weight net / gross	44 / 47 kg
Overall dimensions	840 x 635 x 475 mm
Planing	
Planing width	154 mm
Table length	620 mm
Max. Stock removal	1.5 mm
Number of knives	2
Planer shaft	6000 rpm
Thicknessing	
Clearance width	154 mm
Clearance height	100 mm
Max. Stock removal	2.0 mm
Feed speed	7 m/min
Table Saw	
Table size	620 x 325 mm
Blade Ø	200 mm
Depth of cut	60 mm
Speed	4200 rpm
Shaper / Router	
Collet housing	12 mm
Collet capacity	6 / 8 / 12 mm
Spindle adjustment	42 mm
Speed	9000 rpm

**PACKAGE INCLUDES
WALL MOUNTING BRACKET,
INFLATING GUN, 3 NOZZLES & HOSE**



Wall Compressor cp 16

This new & innovative compressor from Woodster is a must have tool for every home & small workshop. The cp 16 is compact & portable. Weighing only 4 kg this compressor can easily be taken on location. It is free from oil & does not require lubrication, therefore there is no possibility of oils age in transit. Storage of the cp 16 is also no problem as the compressor comes with a wall mounting bracket as standard. The cp 16 is capable of running a wide selection of air tools including tyre inflators, blow guns & many more. The Woodster cp 16 represents incredible value for money.

Performance data

Performance data	
Input Power	1000 W
Air displacement	160 rpm
Working pressure	8 bar
Weight net/gross	5.5 / 6.5 kg
Packaging dimension	390 x 390 x 240 mm
Order No (without kit)	390 6104 000
Order No (incl. kit)	390 6105 000



**PACKAGE INCLUDES
SLIDING TABLE CARRIAGE**



Table saw st 12

Ideal for sawing beams, boards, plates and wood-like materials in the workshop and at the construction sites. These sawbenches represent amazing value for money. Their generous specification fulfills the need for ripping, crosscutting, angle and compound angle cuts. Standard equipment includes: Sliding table carriage running on ball bearings, fence rail adjustable from 90° to 45°, wheel kit, handwheel - allows simple and precise setting of the saw blade, professional fence, table length extension (could be used also as table width extension).

Performance data

∅ blade	315 x 30 x 24 teeth	
Dimensions	1110 x 600 x 1050 mm	
Table size	800 x 550 mm	
Table height	800 mm	
Cutting depth at 90°	83 cm	
Cutting depth at 45°	49 cm	
Sliding table Adjustable	45°	
Sliding table Guide rail	960 mm	
Motor	230 V	400 V
Input	2.2 kW	2.8 kW
Motor speed	2800 rpm	2800 rpm
Order No	390 1302 000	390 1302 905

**INTEGRAL
LASER GUIDE**



Table saw system st 10L

The machine in its basic form can be regarded as a bench top saw, which is light enough to be a portable unit and will quite easily fit into the boot of an average car. The leg stand clips to the machine and simply folds flat when not in use. Wheels are also provided to make movement easy.

With a powerful 2000 Watt motor and top quality TCT blade effortless smooth cutting is assured. A substantial and accurate fence system guarantees precise cuts.



Performance data

Voltage	230 - 240 / 2000 W
No load speed	5700 rpm
Blade diameter	254 mm
Table height	850 mm
Table size	665 x 495 mm
Table size with extens. tables	930 x 495 mm
Cutting width without extension. tables l / r	180 / 330 mm
Cutting width with extension l / r	425 / 495 mm
Depth of cut at 90°	75 mm
Depth of cut at 45°	50 mm
Weight	31 kg
Order No	390 1301 000

PLANER / THICKNESSER: 10" X 6"



Planer / Thicknesser pt 106

Generously proportioned, always
precise, mobile if necessary
- the pt 106

This 10" Planer/Thicknesser has all the features you'd want for precision jointing and thicknessing applications and easy for use. It's a perfect scaled down version of full sized machines at a much higher price. Having a 1,600 Watt motor it handles timber sections easily up to a maximum capacity of 254 x 160 mm. The blades are easy to change and revolve at 8900rpm to leave a clean ripple free finish. The standard equipment includes a substantial surface planing fence which can be tilted to 45 degrees.

All of these and much more are standard with Woodster Planer/Thicknesser.

Performance data

Motor	230 V / 1600 W
Surface planing	
Plane width	254 mm (10")
Max. stock removal	2.5 mm
Thicknessing	
Clearance height/width	6-160 mm (6")
Max. stock removal	2 mm
No. of blade	2
Speed	8900 rpm
Weight net / gross	40 / 46 kg
Order No	390 2203 000

**PLANER / THICKNESSER:
8" X 5"**

Planer / thicknesser pt 85

For those with limited space, but have the need of a combination planer this compact pt 85 is just the number. It's a perfect scaled down version of full sized machines at a much higher price.

Having a 1,250 Watt motor it handles timber sections easily up to a maximum capacity of 204 mm x 120 mm. Four

metal wing feet ensures the machine will remain stable whilst planing longer timber sections. The HSS knives give a smooth finish and keep the amount of sanding time to a minimum.

Made from steel and cast alloy components, the Woodster pt 85 is of sturdy construction and will give years of perfect planing results.



Performance data

Motor	230 V / 1250 W
Surfacing table size	737 x 210 mm
Surface planing	
Plane width	204 mm (8")
Max. stock removal	2 mm
Thicknessing	
Clearance height/width	5 – 120 mm
Max. stock removal	1 mm
No. of blade	2
Speed	8000 rpm
Weight net / gross	24.5 / 28.0 kg
Order No	390 2202 000

**PLANER /
THICKNESSER:
6" X 4"**



Planer / thicknesser pt 65

The smaller brother of the pt 85 for those who do not need the extra large planing and thicknessing capacity. The machine has everything a fully grown planer should have: Heavy-duty construction of steel and cast-alloy components, 1280 W motor, four metal wing feet ensuring stability when handling longer timber, and HSS knives for a smooth surface.

Performance data

Motor	230 V / 1280 W
Surfacing table size	655 x 162 mm
Surface planing	
Plane width mm	152 mm
Max. stock removal mm	2 mm
Thicknessing	
Clearance height / width	5 – 100 mm
Max. stock removal	2 mm
No. of blade	2
Speed	9000 rpm
Weight net / gross	23.5 / 25.5 kg
Order No	390 2201 000

**DESIGN
PROTECTED**

**CAST
IRON
TABLE**



Performance data

Voltage / Power	230 V / 1500 Watt
Sizes L / W / H	610 / 360 / 311 mm
Table size	610 x 360 mm
Spindle adjustment	0 – 40 mm
No Load Speed	8000 – 24000 rpm
Collet capacity	6 / 8 / 12 mm
Spindle lock	Yes
Weight net	30 kg
Order No	390 2103 000

Bench top shaper bs 52

This compact machine offers you all the important features of a big machine at an economic price.

This powerful, robust and competitively priced woodworking machine is great for home woodworkers and DIY enthusiasts

- This is a unique motorized benchshaper
- Motor power 1500 Watt
- No Load Speed: 11.500 to 24.000 rpm
- Adjustable Spindle height from 0 - 40 mm
- Adjustable fences: Enables fast and easy set-up for various work pieces
- Takes 6 / 8 / 12 mm collets

**DESIGN
PROTECTED**



Bench top shaper bs 52

This compact machine offers you all the important features of a big machine at an economic price.

This powerful, robust and competitively priced woodworking machine is great for home woodworkers and DIY enthusiasts

- This is a unique motorized benchshaper
- Motor power 1500 Watt
- No Load Speed: 11.500 to 24.000 rpm
- Adjustable Spindle height from 0 – 40 mm
- Adjustable fences: Enables fast and easy set-up for various work pieces
- Takes 6 / 8 mm collets

**ALLOY
TABLE**

Performance data

Voltage / Power	230 V / 1500 Watt
Sizes L / B / T	610 / 360 / 311 mm
Table size	610 x 360 mm
Spindle adjustment	0 – 40 mm
No Load Speed	8000 – 24000 rpm
Collet capacity	6 / 8 / 12 mm
Spindle lock	Yes
Weight net	20 kg
Order No	390 2102 000

ECONOMIC PRECISION SHAPER/ROUTER



Bench top shaper/router bs 50

This compact machine offers you all the important features of a big machine at an economic price. While the adjustable split fence facilitates your work, the variable speed control ensures a smooth surface with any material. Further features are the adjustable cutting height to adapt the tool to different work piece sizes, and the mitre gauge to hold narrow work pieces.

Performance data

Performance data	
Motor	230 V / 1050 Watt
Table size	600 / 460 mm
Table height	365 mm
Spindle adjustment	0 – 35 mm
No Load Speed	15000 – 27000 rpm
Collet Capacity	6 mm & 8 mm
Clearance height/width	1/2" & 1/4" (UK)
Spindle Lock	Yes
Throat Plates	3
Weight net / gross	18.5 / 20 kg
Order No	390 2101 000

**FILTRATION:
0,5 MICRON**



DUST EXTRACTOR dc 04

A magnificent little workhorse at an incredible price!

This dust collector out-performs all types of wet / dry vacuum cleaners when it comes to wood dust extraction. A wet / dry vacuum is inefficeint when extracting large amounts of wood dust and therefore becomes a costly error to the unsuspecting end user. For minimum additional outlay it is now possible to purchase a machine which does the job it is designed for. Namely wood extraction! Use common sense and buy the right tool for the job. Excellent for the small workshop.



Performance data

Voltage	230 – 240 / 1100 W
Capacity	50 l metal container
Airflow	183 m ³ /h
Hose	100 mm
Collection hose	100 x 1500 mm
Filtertration	0.5 microns
Noise level	85 dB
Weight	11 kg
Order No	390 6302 000

**BEST QUALITY
HOSE WITH
METAL WIRE
INSIDE**

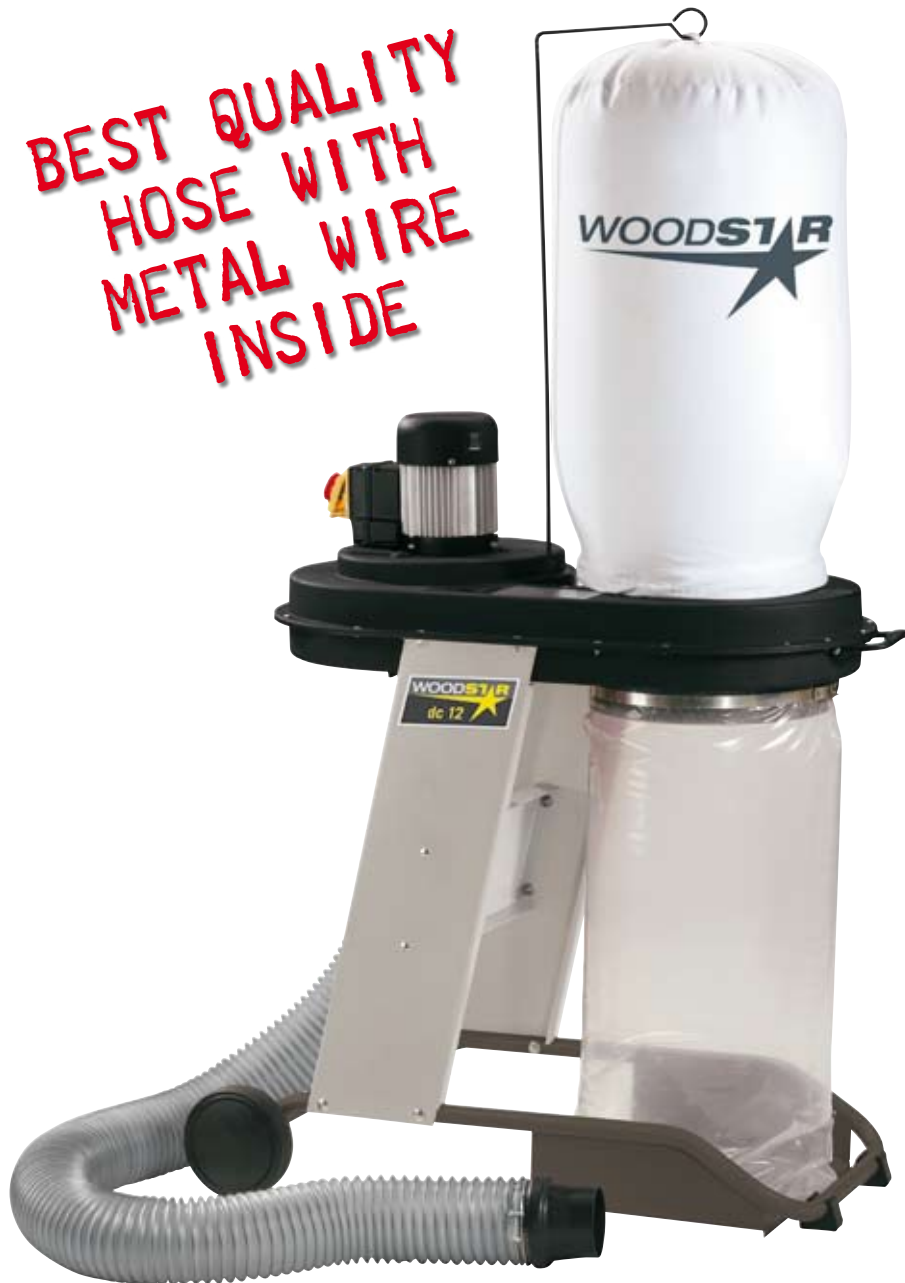

Dust collector dc 12

Effective dust collection not only keeps your workshop cleaner and more pleasant to work in, it can also keep you healthier. Our systems feature powerful motors and convenient collection bags - so they're ideal for just about any-sized woodworking operation.

A magnificent little workhorse at an incredible price!

Performance data

Dimensions L x W x H	775 x 450 x 1150 mm
Partial vacuum	1000 Pa
Filter surface	1 m ²
Air capacity	1150 m ³ /h
Hose length	2000 mm
Hose connector ø	100 mm
Motor	230 V
Input	550 W
Weight	25 kg
Order No	390 6301 000

NEW



Flip Over Crosscut/Mitre/Table Saw fs 08

This new & innovative saw from Woodster is a combination of three saw types in one machine: Crosscut / Mitre / Table Saw.

It turns in a few seconds from cross cut saw into a bench top circular sawing machine. The fs 08 is torsion resistant design and construction for best possible cutting quality. Combined with a Powerful 1400 watt motor, maintenance-free.

Integral leg design increasing durability and easy of use.



Performance data

Motor	230 V
Rated input power	1400 W
Cutting width – cross cutting mode 90 / 45°	120 / 85 mm
Cutting depth – cross cutting mode 90 / 45°	58 / 40 mm
Cutting height – table mode 90°	52 mm
Cutting height – table mode 45°	25 mm
No-load speed	5.000 rpm
Saw blade Ø	216 mm
Order No	390 1601 000

**WITH SOLID
ALUMINIUM
BASE**



Mitre saw sx 8

This model is a small, economic mitre saw for the do-it-yourselfer doing occasional cuts.

With its fully machined aluminium base, it is light and therefore easily transported. Despite its light weight, however, the sx 8 is versatile, permitting the execution of exact mitre, bevel and compound cuts with the help of the scales on table and arm.

Performance data

motor	230 V / 1200 W
speed	5000 rpm
blade diameter	210 mm
bore	30 mm
table tilting mitre angle	left 47° / right 47°
table tilting slope angle	0° to 45°
cutting height/width	120 x 60 mm (90° / 90°)
cutting height/width	80 x 60 mm (90° / 45°)
cutting height/width	80 x 45 mm (45° / 45°)
packing size	500 x 365 x 350 mm
weight net / gross	9.5 / 10.5 kg
Order No	390 1101 000

**WITH LIGHT
PLASTIC
BASE**



Mitre saw sx 8p

This model is a small, economic mitre saw for the do-it-yourselfer doing occasional cuts.

With its plastic base, it is light and therefore easily transported. Despite its light weight, the sx 8p is versatile, permitting the execution of exact mitre, bevel and compound cuts with the help of the scales on table and arm.

Performance data

motor	230 V / 1200 Watt
speed	5000 rpm
blade diameter	210 mm
bore	30 mm
table tilting mitre angle	left 47° / right 47°
table tilting slope angle	0° to 45°
cutting height/width	120 x 60 mm (90°/90°)
cutting height/width	80 x 60 mm (90°/45°)
cutting height/width	80 x 45 mm (45°/45°)
weight net / gross	7 / 9 kg
Order No	390 1101 920

**INTEGRAL
LASER GUIDE**

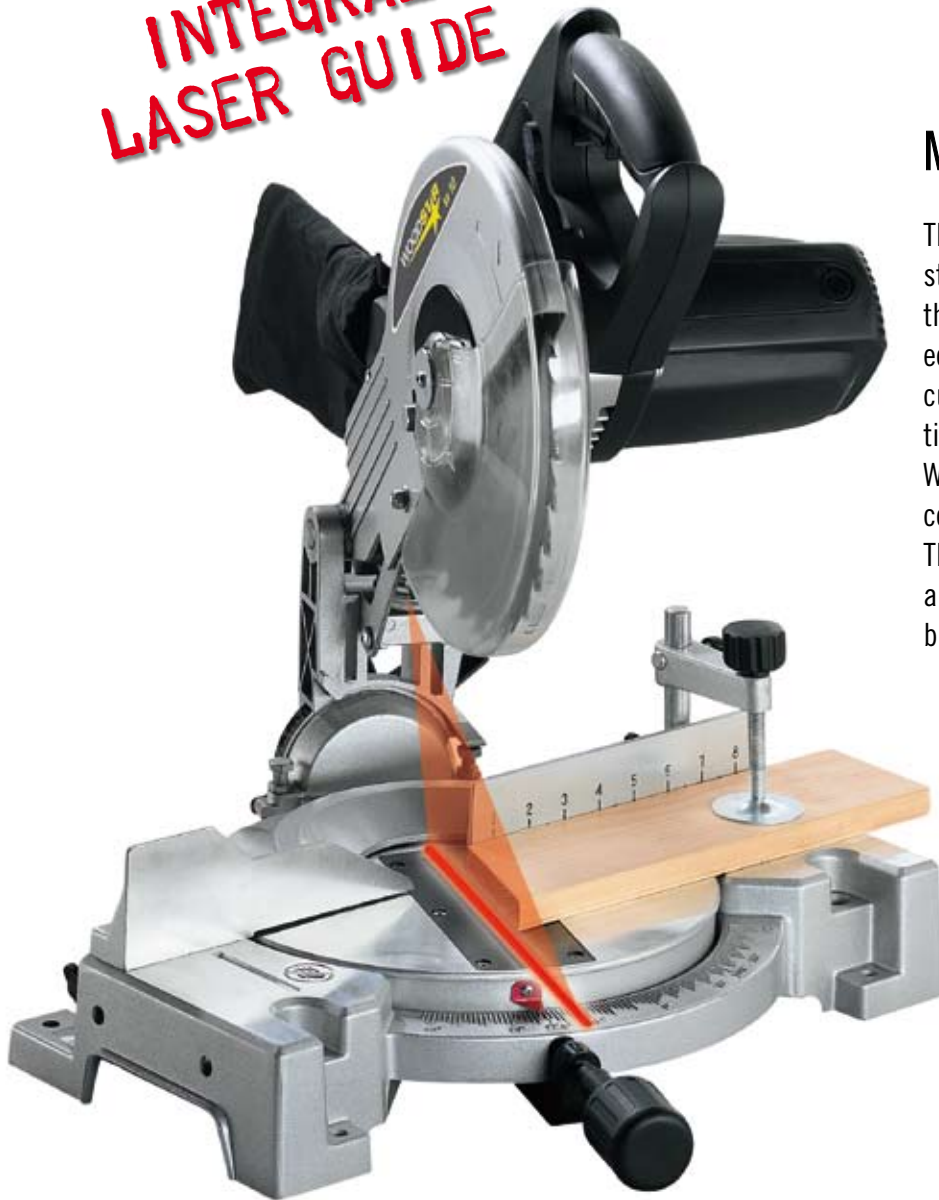

Mitre saw sx 10 L

This laser-controlled mitre saw sets new standards for the professional user and the demanding do-it-yourselfer. It executes straight, cross or compound mitre cuts in wood, plastics or aluminium. The tilting table covers a range of $2 \times 45^\circ$. With its sloping angle of 45° , it easily copes with double mitre cuts of $45 \times 45^\circ$. The high cutting quality ensures exact and clean cuts. The sx 10 L has a light but solid base of aluminium.

Performance data

motor	230 V / 1800 Watt
speed	5000 rpm
blade diameter	254 mm
bore	30 mm
Adjustments	$0^\circ / 15^\circ / 22.5^\circ / 30^\circ / 45^\circ$
table tilting mitre angle	left 45° / right 45°
table tilting slope angle	0° to 45°
cutting height/width mm	130 x 80 mm ($90^\circ / 90^\circ$)
cutting height/width mm	90 x 80 mm ($90^\circ / 45^\circ$)
cutting height/width mm	90 x 40 mm ($45^\circ / 45^\circ$)
weight net / gross	12,5 / 13,5 kg
Order No:	390 1103 000

**LOWER GUIDE
RAILS**



Slide compound mitre saw sl 10 d

Our most powerful portable mitre saw with an exceptional cutting capacity for the professional user and the demanding do-it-yourselfer. The heavy-duty machine is fitted with an 1800 W motor for powerful sawing, and allows precise cross, bevel and double-compound cutting. The machine weighs 17 kg, but is compact enough to be taken along to building sites. Accuracy and remarkable cutting capacity is ensured by the guide bars, while your hands are protected by the fully enclosed saw blade guard.

Performance data

Performance data	
motor	230 V / 1800 W
speed	5000 rpm
blade diameter	254 mm
bore	30 mm
table tilting mitre angle	left 45° / right 45°
table tilting slope angle	0° to 45°
Mitre stops left and right	0°, 15°, 22.5°, 31.6°, 45°
Cross cut at 90°	310 x 80 mm
Mitre cut at 45°	210 x 80 mm
Bevel cut at 45°	310 x 45 mm
Compound cut at 45°	210 x 45 mm
weight net / gross	17.0 / 20.0 kg
Order No	390 1202 000

LASER **NEW**



Slide compound mitre saw sl 8lu

The “Woodster sl 8lu” Sliding Compound Mitre Saw is perfect for general daily DIY use. Ideal for miter, bevel and compound angle cuts, this compound miter saw from Woodster features a dual slide rail. Designed to be versatile in application, it accurately & precisely cuts hard & soft wood, processed timbers, plastic. Light-weight, portable design with built-in carry handle for easy transporting from worksite to worksite. The 24-tooth carbide tipped blade stays sharp and makes clean cuts.

Performance data

motor	230 V / 1500 W
speed	5000 rpm
blade diameter	210 mm
table tilting mitre angle	left 45° / right 45°
table tilting slope angle	0° to 45°
Cross cut at 90°	340 x 65 mm
Mitre cut at 45°	240 x 65 mm
Bevel cut at 45°	340 x 35 mm
Compound cut at 45°	240 x 35 mm
weight net / gross	16 / 19 kg
Order No:	390 1204 000

**UPPER GUIDE
RAILS**



Slide compound mitre saw sl 10 u

The sl 10u is the best of the Woodstar mitre saws.

At a weight of 22.5 kg it is extremely portable whilst giving an impressive array of accurate cross, bevel and double compound mitre cuts. Having a powerful 1800 Watt motor, this saw is ideal for both on site and workshop use and offers increased cutting capacity and accuracy due to its dual sliding rails. Standard timber sections and man made boards are cut with ease.

Performance data

Motor	230 V / 1800 Watt
Speed	5000 rpm
Blade diameter:	254 mm
Bore	30 mm
Table tilting mitre angle	left 45° / right 45°
Table tilting slope angle	0° to 45°
Mitre stops left and right	0°, 15°, 22.5°, 31.6°, 45°
Cross cut at 90°	320 x 65 mm
Mitre cut at 45°	220 x 65 mm
Bevel cut at 45°	320 x 45 mm
Compound cut at 45°	220 x 45 mm
Weight net / gross	22.5 kg / 24.0 kg
Order No	390 1201 000

**INCL.
LASER & BASE
UNIT**



Slide compound mitre saw sl 10 lu

A powerful mitre saw, ideal for on-site or workshop use, that is fitted with dual sliding rails for greater accuracy & increased cutting capacity. Features include a double bar slide system, which allow extended cutting capacity and greater accuracy. A part of standard equipment is also the Laser, which is for improved cutting vision, faster setup, increased accuracy and safer operation. The standard base unit provides a high strength to weight ratio.

Performance data

ø blade	254 mm
Dimensions	515 x 770 x 580 mm
Weight	20.0 kg
Mitre angle range	45° left and right
Bevel angle range	0° – 45°
Max. Capacity	
Cross cut at 90°	70 x 310 mm
Mitre cut at 45°	70 x 210 mm
Motor	230 V / 50 Hz
Input	1900 W
No load speed	5000 rpm
Order No	390 1203 000

**CUTTING TO
PRECISION**



Scroll saw sd 16

The Woodster sd 16 is the scroll saw model makers and do-it-yourselfers have been waiting for. With this machine, even complicated cuts in wood, plastics, metal, Plexiglas or plaster are executed with a perfect result. The table top tilting over 45° allows most versatile work, so you are prepared for any tasks required.

Performance data

Motor	230 V / 120 Watt
Table size ϕ	255 x 410 mm
Sawblade length	133 mm
Max. cutting height	0 – 50 mm
Working depth	55 / 405 mm
Table tilting	6 / 8 / 12 mm
Speed	1425 rpm
Weight net / gross	12.6 / 10.1 kg
Order No	390 1401 000

INDUCTION-MOTOR

Belt & Disc Sander bd 75

A small bench top Belt & Disc Sander intended for the serious model maker, craftsmen, and for general hobby work; this versatile, combined belt and disc sander makes easy work of achieving a fine & smooth finish on component pieces made from wood, plastic and non ferrous metal. All in all, this is a very effective small sanding machine with a host of applications in the hobby workshop



Performance data

Performance data	
Motor	230 V / 50 Hz / 250 Watt
Diameter of Disc	125 mm
Table Size Disc l x w	184 x 98 mm
Table tilting range Disc	0° to 45°
Disc speed	2850 rpm
Dust Extraction Outlet Disc	45 mm
Belt Size	25.4 x 762 mm
Table Size Belt l x w	148 mm
Table tilting range Disc	0° to 60°
Belt speed	820 rpm
Dust Extraction Outlet Belt	45 mm
Weight gross /net	8.4 / 7.2 kg
Order No	390 3301 000

**HEAVY DUTY CAST
IRON TABLE**



Woodstar Oscillating Sander os 58

Sanding deep and wide work pieces, front edges, narrow inner curves, horizontal, vertical, diagonal, with or across the grain: it's all part of the daily work with the Woodstar os 58

Powered by an 0.6 HP motor which provides sufficient power in any applications. Rotating and oscillating action ensures exceptional finishing results. On-board accessory storage ensures convenient storage of all drums and table inserts plates.

User-friendly features including dust collection port which allows connection to dust extractor equipment for a cleaner and safer working equipment.

It's a compact unit that can be easily stored when not in use.

Performance data

Motor	230 V / 50 Hz / 450 Watt
No Load Speed	2000 rpm
Oscillating per minute	58
Table size	375 x 300 mm
Sanding sleeves	1/2", 3/4", 1", 1 1/2", 2", 3"
Dust Port	36 mm
Net weight	14.6 kg
Order No	390 3401 000

Includes

Sanding sleeves: 1/2", 3/4", 1", 1-1/2", 2" & 3"
Rubber sanding drums: 3/4", 1", 1-1/2", 2" & 3"
Table inserts: 1/2", 3/4", 1", 1-1/2", 2" & 3"
Spindle washers: 5/8", 7/8", 1-3/4", S 2-3/4"

**INDUSTRIAL
TOOLS CHOP SAW
6IN. DIA.**



Metall cutter mc 06

Woodster - Industrial Tools Chop Saw – 6 in. Dia.

Quickly cuts conduit, steel pipe, drywall studs, PVC and rebar with a 1.1 hp maximum developed universal motor and 6 in. abrasive wheel. Head lock-down chain and handle make the saw portable.

Performance data

Performance data	
Motor	230 V / 780 Watt
Speed	7400 rpm
Blade diameter	150 mm
Cutting height / width	35 x 50 mm (90° / 90°)
Cutting height / width	35 x 16 mm (90° / 45°)
Packing size	410 x 250 x 260 mm
Weight net / gross	4.9 / 5.5 kg
Order No	390 3102 000

PORTABLE VARIABLE SPEED BANDSAW

METAL BANDSAW PB 06

This bandsaw is small and light and thus more suitable for the smaller workshop where space is at a premium. It is made to a high standard and has all the features you would expect from a quality machine. Also it's lightweight for easy transport to the job site. It's light enough to be carried about or stored under a bench. A part of standard equipment are needle bearing mounted spindle and three wheel bearing blade guides for smooth, accurate cuts.



Performance data

Dimensions L x W x H	540 x 260 x 260 mm
Cutting width	120 mm
Cutting height	100 mm
Cutting depth	60 mm
Sawblade length	1150 x 0.6 x 13 mm
Motor	230 V
Input	700 W
Weight	6.2 kg
Order No	390 1501 000

ECONOMIC TABLE GRINDER



Grinder gg 66

If you are looking for an economic table grinder of good quality for your small workshop, Woodster has the right model for you. The gg 66 comes with two eye guards and two tool rests, all of them adjustable, as well as two grindstones, one of coarse and one of medium-sized grain.

Performance data

Performance data	
Motor	230 V / 150 W
∅ grinding disc bore	12.7 mm
Motor speed	2950 rpm
Grinding disc width	16 mm
Weight net / gross	6.3 / 7.5 kg
Order No	390 3101 000

**DESIGN
PROTECTED**

200 mm (8") Wet Grinding System



IDEAL FOR HOME AND THE SMALL WORKSHOP
Correct grinding and honing is an art in and of itself. Without training and experience, costly mistakes can be made and expensive tooling ruined.

This Wet stone sharpening system offer superb, professional results and a razor sharp finish every time. With total accuracy and sharpening efficiency this Wet stone sharpening system is easy to use even for a beginner. Ideal for the home and small workshop and with a comprehensive range of accessories, it is perfect in producing sharp cutting edges to knives, scissors and tools. Extensive accessories included with the standard equipment:

Performance data	
L / W / H	360 / 285 / 275 mm
Grinding stone size	200 x 40 mm
Stone grid	K 220
Material	top-quality grindstone with grinding grains of aluminium oxide
Leather honing wheel ø	200 x 30 mm
Weight approx.	13.5 kg
Input	120 W
Order No	390 3201 000

- Industrial induction - type motor for longlasting smooth performance
- Includes a special stone containing grain of aluminium oxide to achieve the perfect grinding results at a much faster time, also ideal for HSS tools
- Includes Jig for straight edges, plane irons, ripping chisels
- Includes Angle setting jig for measuring exact angles and settings
- Break - proof water tank
- Removable Leather Honing wheel. After Sharpening, it removes the burr to give you a smooth edge.

Standard Accessoires



Jig for straight edge chisels, Jig for knives, Abrasion Paste, Angle Master



**EXTRACTS UP TO
50 LITRES OF
WATER PER DAY**

CFC free Dehumidifier: dh 65

Ideal for the home, workshop and office use, the Woodster dh 65 removes moisture from individual areas and rooms to prevent damp & moisture related damage occurring to furniture, upholstery & clothing. It extracts up to 50 litres of water per day, & features 'Wet' and 'Dry' settings for achieving the desired level of humidity.

- CFC free Dehumidifier
- Removes up to 50 Litres in 24 hours (30° C / 80 % relative humidity)
- Removes up to 30 Litres in 24 hours (27° C / 60 % relative humidity)
- 7 litre water container.
- 850 W motor.
- Includes humidistat, full tank indicator, dust filter, & castors for mobility
- Continuous Drain Facility
- Adjustable Humidity Control

Performance data

Motor	230 V / 50 Hz / 850 W
Moisture extraction rate	50 Litres in 24 hours (30° C / 80 % relative humidity) 30 Litres in 24 hours (27° C / 60 % relative humidity)
Maximum discharge pressure	2.6 Mpa
Maximum suction pressure	1.0 Mpa
Cooling agent	R407c/600 g
Use range	5° C – 32° C
Tank capacity	7 ltr.
Weight br/ne	28 / 25 kg
L x W x H	350 x 603 x 455 mm
Order No	390 6501 000

ECO
MODEL

SPLITTING
POWER 4 TON

Handy, powerful operator: lh 45

This robust log splitter has a stable, torsion-resistant coated steel construction. The lh 45 gives security by a two-handed safety control and has the distinction of being quiet running. It effortlessly cracks wood of up to 37 cm length and up to 25 cm diameter with his high splitting power.



Performance data

Motor	230 V / 50 Hz/ 1.5 kW
Speed	2850 rpm
Splitting power	4 t
Wood length	max. 370 mm
Wood dia.	max. 250 mm
Cylinder rise	250 mm
Weight gross/net	43 / 41 kg
Order No	390 5201 000

**ECO
MODEL**

**SPLITTING
POWER 5 TON**



Handy, powerful operator: lh 52

This robust log splitter has a stable, torsion-resistant coated steel construction.

The lh 52 gives security by a two-handed safety control and has the distinction of being quiet running.

It effortlessly cracks wood of up to 52 cm length and up to 25 cm diameter with his high splitting power.

**INCL.
BASE UNIT**

Performance data

Motor	230 V / 50 Hz / 2.2 kW
Speed	2850 rpm
Splitting power	5 t
Wood length	max. 520 mm
Wood dia.	max. 250 mm
Cylinder rise	375
Stroke approach	3.13 cm/s
Stroke reverse	4.69 cm/s
Table height with base	820 mm
Weight gross/net	46,5 / 44 kg
Order No	390 5202 000

**SPLITTING
POWER 6 TON**

Heating with wood – naturally
and inexpensively – lv 60 eco
log splitter makes it real

- robust hydraulic log splitter, torsion-resistant coated steel construction
- optimal 2-hand-safety control with hand guard
- low speed, low noise pollution
- stable, massive splitting knife
- big, stable 3-position plug-in table for short and long log lengths
- continuous adjustable splitting stroke usable from short to long wood



Performance data

Motor	400 V / 50 Hz / 3.0 kW
Speed	2800 rpm
Cylinder rise	50 cm
Splitting power	6 t
Wood length	max. ca. 55 / 80 / 105 cm
Stroke approach	5 cm/sec
Stroke reverse	16 cm/sec
Order No	390 5306 000

**SPLITTING
POWER 7,5 TON**

Naturally heating with wood – lv 80 hydraulic log splitter

- robust hydraulic log splitter, torsion-resistant coated steel construction
- optimal 2-hand-safety control with hand guard
- low speed, low noise pollution
- low maintenance plastic guidance
- stable, massive splitting knife
- big, stable table
- continuous adjustable splitting stroke
- universal applicable from short to long wood



Performance data

Motor	400 V/50 Hz/ 3,5 kW
Speed	1420 rpm
Cylinder rise	48 cm
Splitting power	7,5 t
Splitting table size	400 x 330 mm
Table height	315 / 575 / 760 mm
Wood length	max. ca. 58 / 78 / 104 cm
Stroke approach	5,4 cm/sec
Stroke reverse	11,7 cm / sec
Weight gross / net	125 / 115 kg
Order No	390 5305 000

WOODSTAR

WOODSTAR
EXCLUSIVELY
ONLY HERE

**SPLITTING
POWER 8.5 TON**



Naturally heating with wood – Iv 90 hydraulic log splitter

- robust hydraulic log splitter, torsion-resistant coated steel construction
- optimal 2-hand-safety control with hand guard
- low speed, low noise pollution
- low maintenance eight fold plastic guidance
- stable, massive splitting knife
- big, stable table
- continuous adjustable splitting stroke
- universal applicable from short to long wood

Performance data

Motor	400 V / 50 Hz / 3.5 kW
Speed	1400 rpm
Cylinder rise	48 cm
Splitting power	8.5 t
Splitting table size	280 x 225 mm
Wood length	max. ca. 55 / 80 / 106 cm
Stroke approach	5.5 cm/sec
Stroke reverse	25 cm/sec
Order No	390 5304 000

NEW

**simple handling with
double-swinging-out table**



FREE

**WORLDWIDE
PATENT PENDING**



In one go you get 6
fillet wood pieces
(additional prepara-
tion of ignition
wood is no more
necessary)

**SPLITTING
POWER 8.5 TON**

NEW

Naturally heating with wood – If 90 hydraulic log splitter

OPTIONALLY



- robust hydraulic log splitter, torsion-resistant coated steel construction
- optimal 2-hand-safety control with hand guard
- low speed, low noise pollution
- low maintenance fourfold plastic guidance
- stable, massive splitting knife
- big, stable table
- continuous adjustable splitting stroke
- universal applicable from short to long wood

NEW

**simple handling with
double-swinging-out table**

Performance data	
Motor	400 V / 50 Hz / 3.5 kW
Speed	1450 rpm
Cylinder rise	48 cm
Splitting power	8.5 t
Splitting table size	280 x 200 mm
Wood length	max. ca. 54 / 89 / 125 cm
Stroke approach	6 cm/sec
Stroke reverse	24 cm/sec
Order No	390 5401 000



**SPLITTING
POWER 10 TON**

NEW

OPTIONALLY



Naturally heating with wood – If 100 hydraulic log splitter

- robust hydraulic log splitter, torsion-resistant coated steel construction
- optimal 2-hand-safety control with hand guard
- low speed, low noise pollution
- low maintenance fourfold plastic guidance
- stable, massive splitting knife
- continuous adjustable splitting stroke
- universal applicable from short to long wood

Performance data	
Motor	400 V / 50 Hz / 4.1 kW
Speed	1450 rpm
Cylinder rise	55 cm
Splitting power	10 t
Wood length	max. ca. 59 / 88 / 135 cm
Stroke approach	4,5 cm/sec
Stroke reverse	18 cm/sec
Order No	390 5402 000

NEW

**simple handling with
double-swinging-out table**





Your direct contacts

Serdar Eraslan
Export Manager

Phone: 0049/8223/4002-47
Mobile: 0049/178/44 00 210
Fax: 0049/8223/4002-93

serdar.eraslan@scheppach.com

Robert Schultheiß
Export

Phone: 0049/8223/4002-85
Fax: 0049/8223/4002-93

robert.schultheiss@scheppach.com

Barbara Schneider
Export

Phone: 0049/8223/4002-34
Fax: 0049/8223/4002-93

barbara.schneider@scheppach.com

Maximiliane Kühner
Export

Phone: 0049/8223/4002-35
Fax: 0049/8223/4002-93

maximiliane.kuehner@scheppach.com

Responsibility cannot be accepted for translation or printing errors. We reserve the right to change the specification without prior notification. Standard delivery specification may require partial self assembly.